

CHANGE PARTS & SPARE PARTS



MEFE



MEFE

SUMMARY



MEFE



- YOU HAVE THE MACHINES AND WE HAVE THE PARTS.!
- In the production process for foods and beverages, filling, labeling, Bottling/ Packaging are vital constituents.
- You have a Line of Hot Melt, Pressure Sensitive and/or Cold Glue Labelers utilize European technology machines to provide extremely accurate label placement and are engineered to last. We may supply the entire range of components for LABELLER, FILLER, WASHERS, RINSERS, PACKERS FOR remanufactured or new All type machine's,.
- We provide design, manufacture and supply of change part systems for, All type machine's, WE CAN ALSO SUPPLY PARTS FOR Blow moulding Machines and Conveyor systems PARTS FOR PERMANENT HIGH PERFORMANCE.
- An important element for the smooth operation of your production line in packaging / bottling industry is the use of high quality parts and line technology. We offer you original or better than original components and spare parts at much lower prices so that you are always on the safe side and saving money.
- Today we are successfully meeting the demands of entire range of parts and components for Beer, Liquor, Food and Beverage Industry with and extended focus on Pharmaceutical, Cosmetics, Chemical, Lube industry as well as household, health and personal care products. With the gained experience and process expertise, we are also able to meet the customized parts demands in exact specifications as demanded by our customers.
- QUALITY AND SERVICE
- Commitment to Quality and Customer Satisfaction is vital to us and our customers prove our credibility in this business since 2001. Our staff is fully familiar with the products and customer requirements in everyday business. We endeavor for excellence with quality, competitive pricing and the best services all the time.
- Mefe Machinery will supply new Bottle Handling Change Parts manufactured to the highest standards. We will engineer your project on the latest 3D Technology and deliver change parts that fit precisely on your machine complete with drawings and parts list for each package.

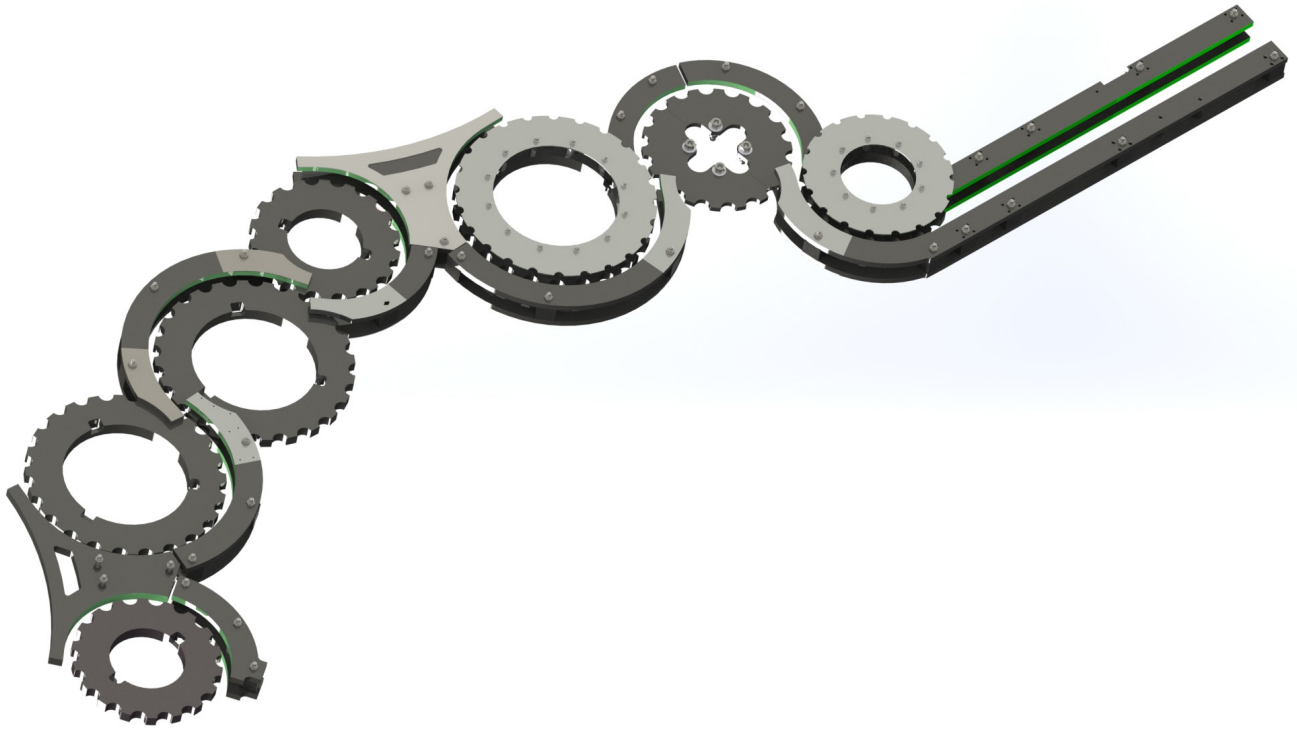

BOTTLE FILLER STAR WHEELS CHANGE PARTS

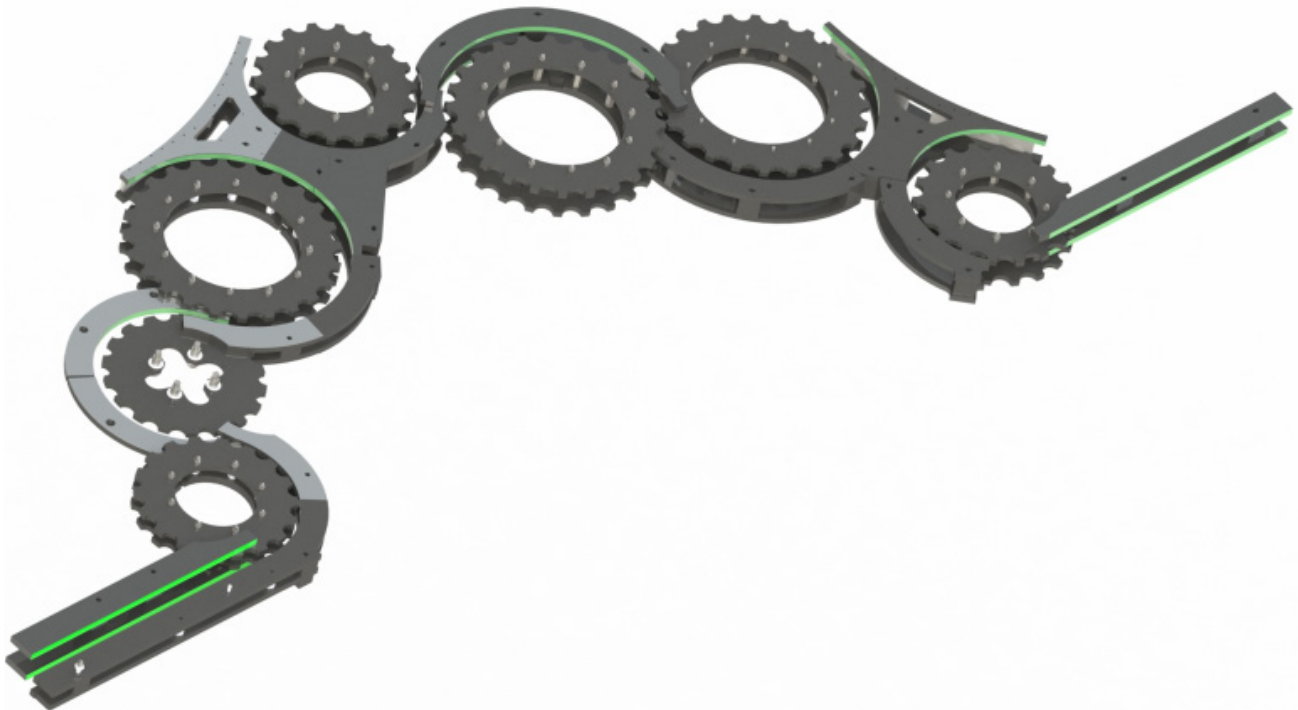

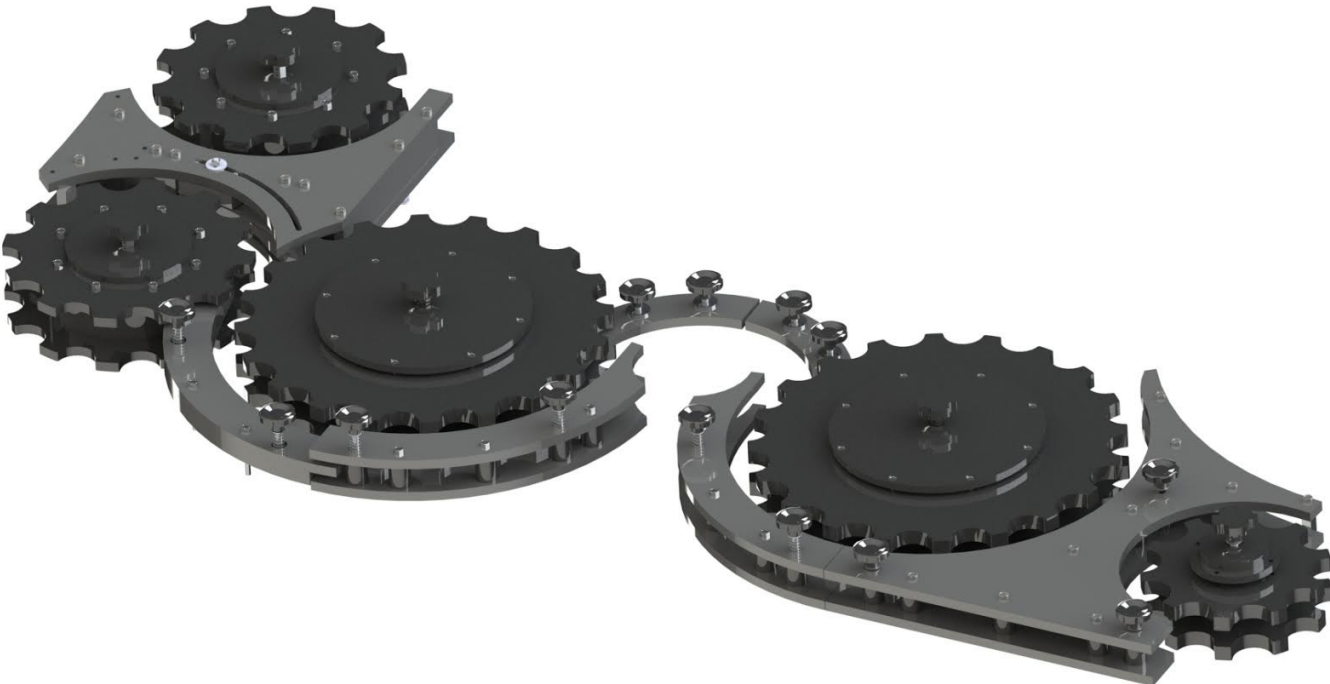

FILLING and LABELLING STAR WHEELS

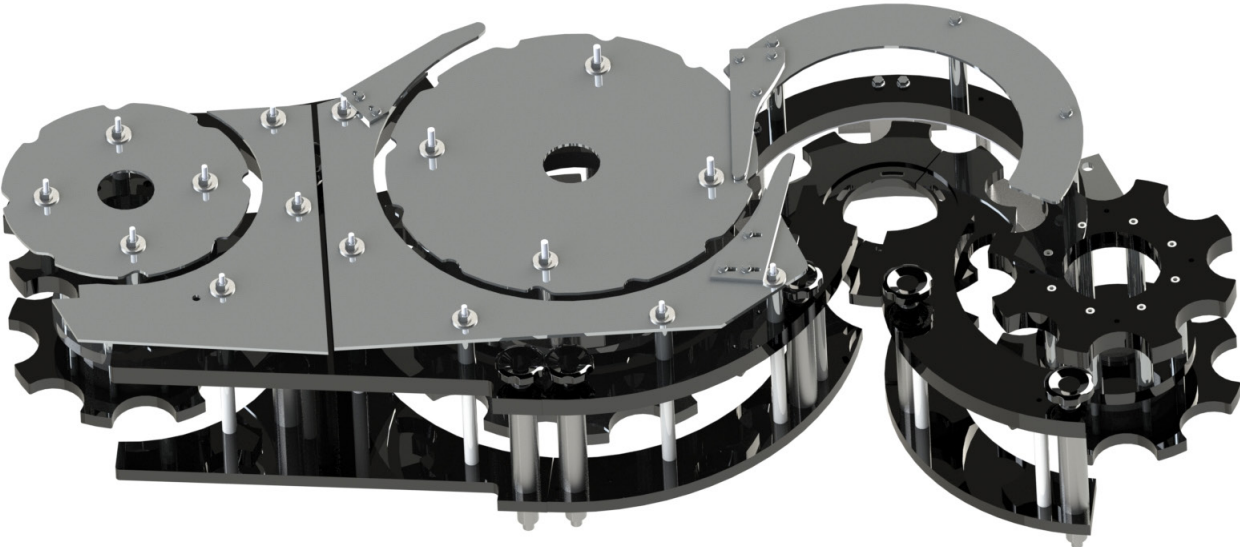

FILLING STAR WHEELS

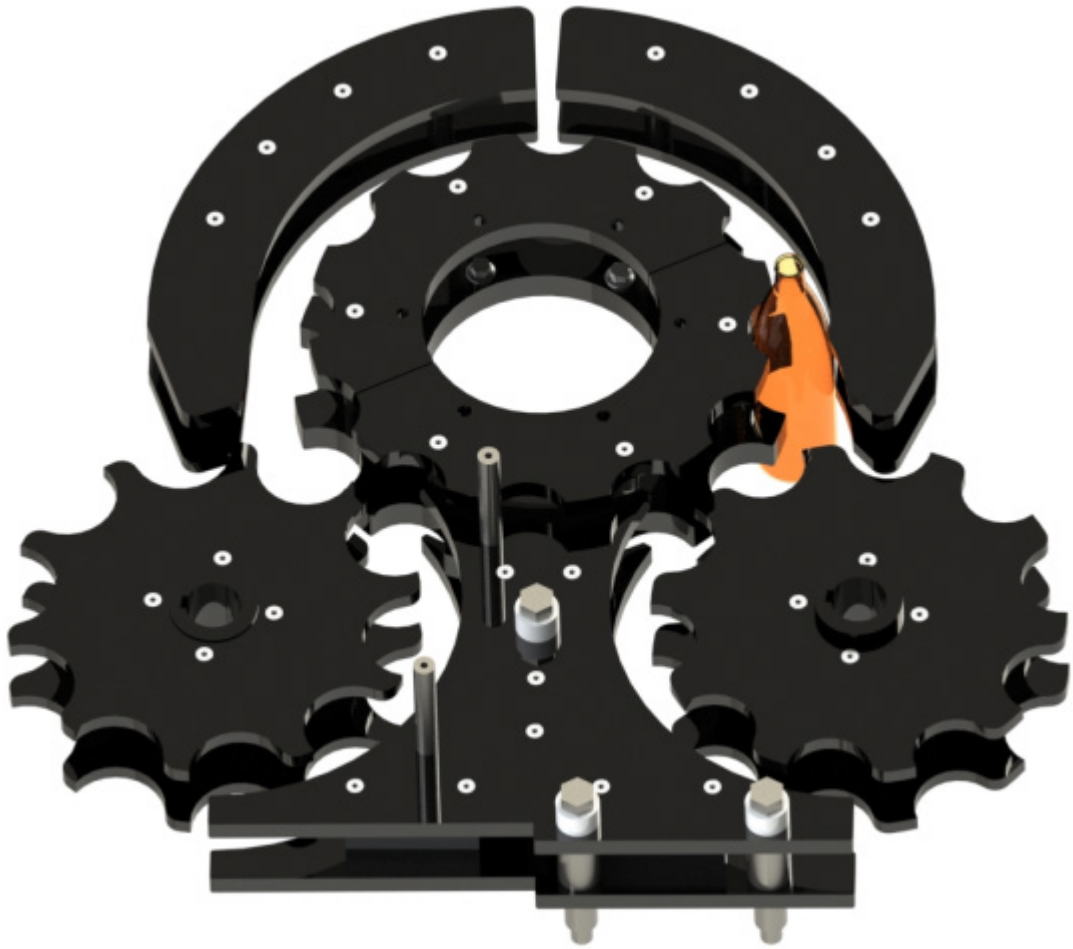

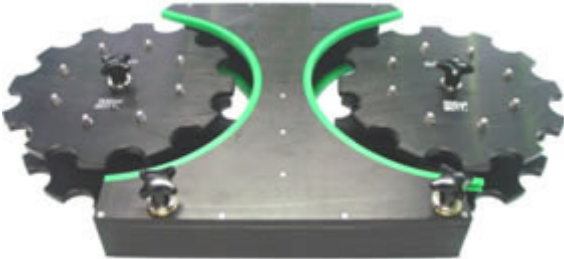



FILLING MACHINE CHANGE PARTS

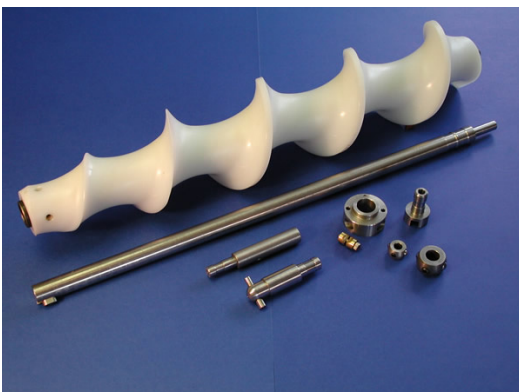
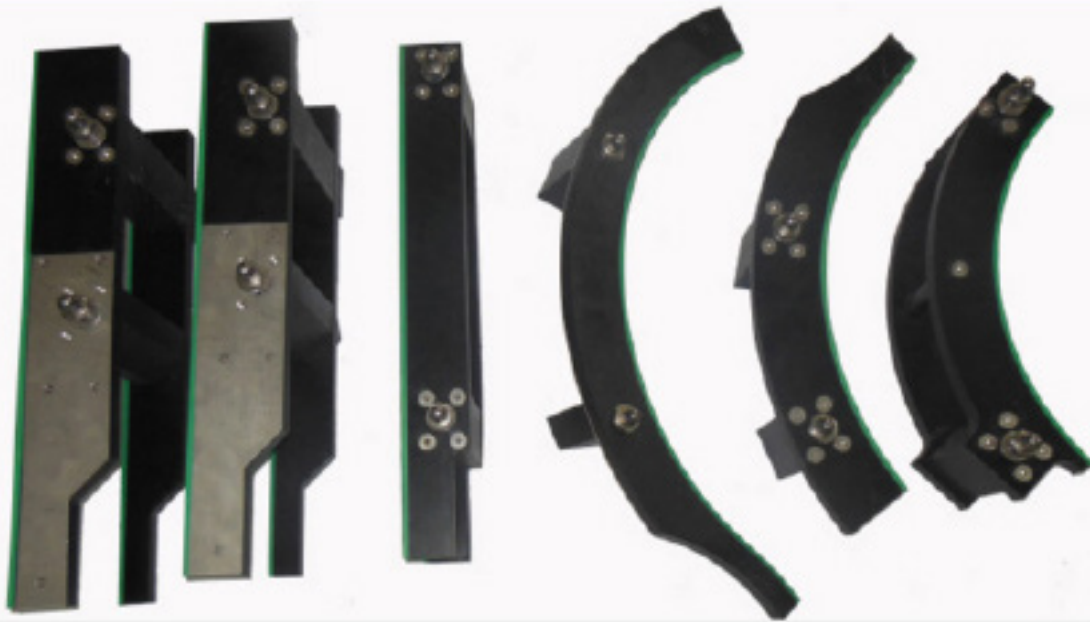

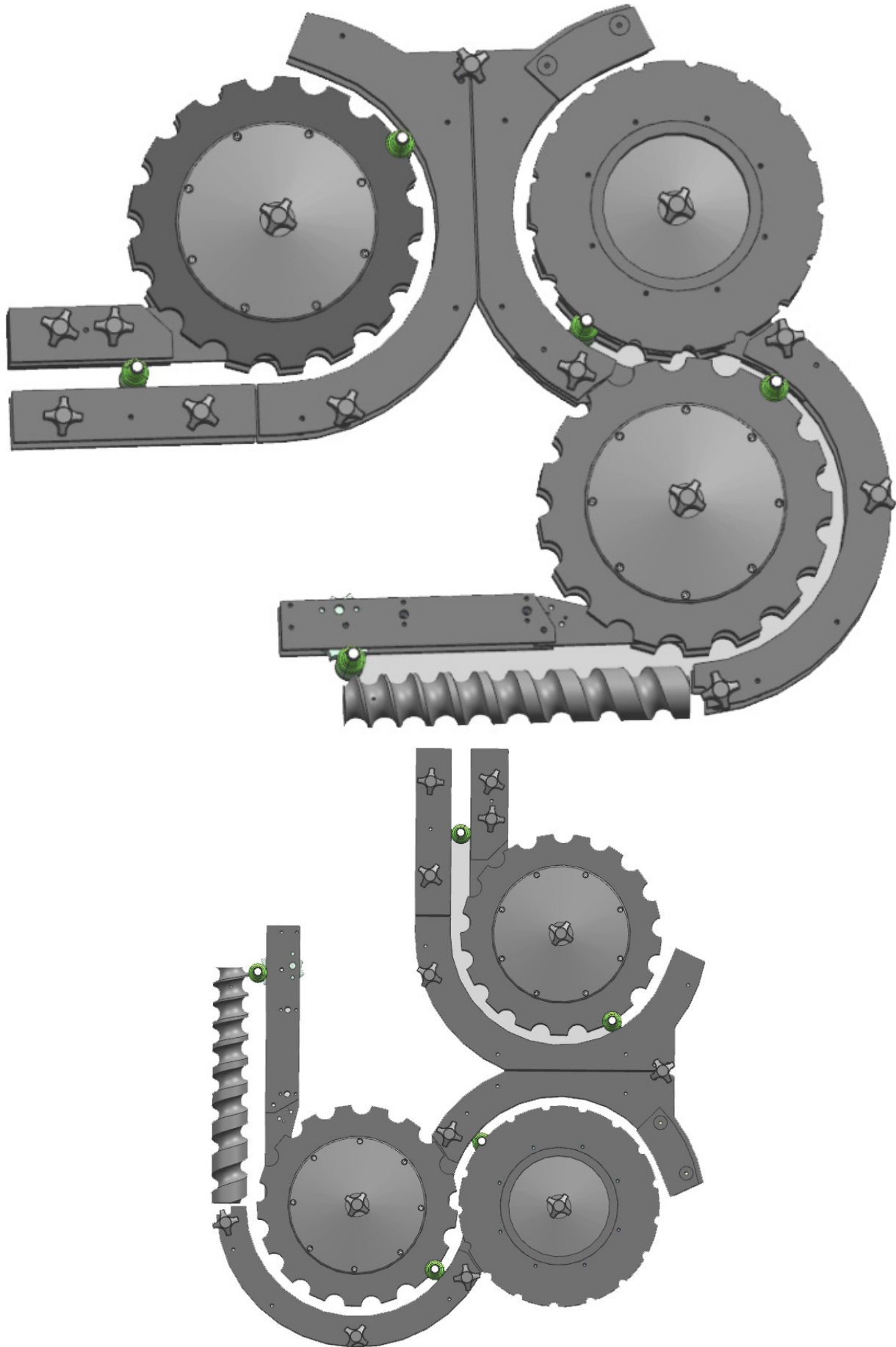



• Filling & Capping Machine Starwheel



- We have manufactured Changeparts for all the machines mentioned below. We are also able to supply neck grips as and when required. The set of parts shown below was for an Ave 24 head right to left rinser. You will note the outfeed star has rather a peculiar shaped pocket, this was done deliberately to allow for the bottle to rotate from an inverted position back to upright. Without this clearance the bottle would have clashed with the star causing major problems in that area.
- Our ultra high molecular weight polyethylene UHMWPE 1000 characteristic features such as:
 - high abrasion resistance
 - high notched impact strength
 - low coefficient of friction
 - high chemical and corrosion resistance
 - no absorption of humidity

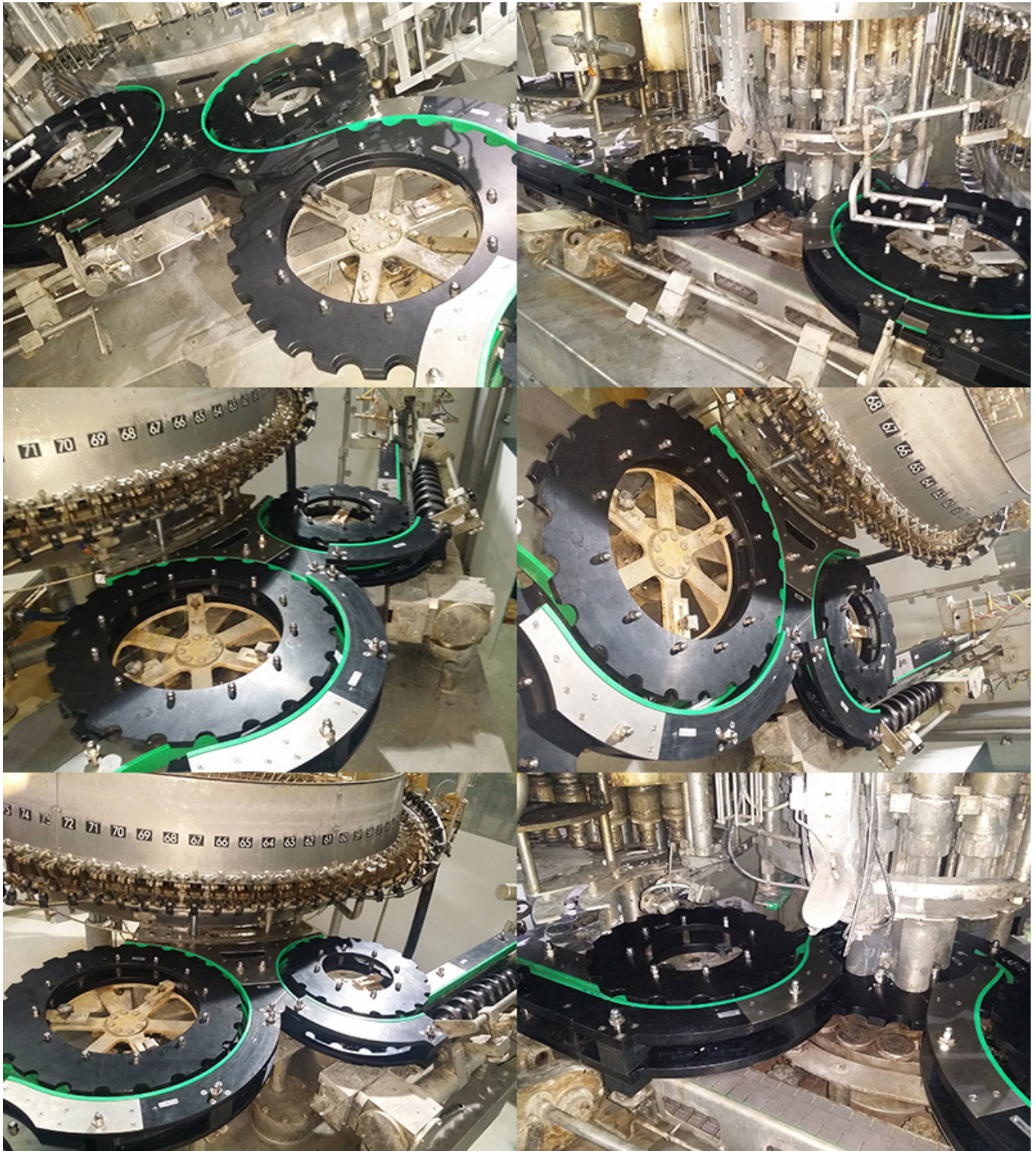

KHS CHANGE PARTS

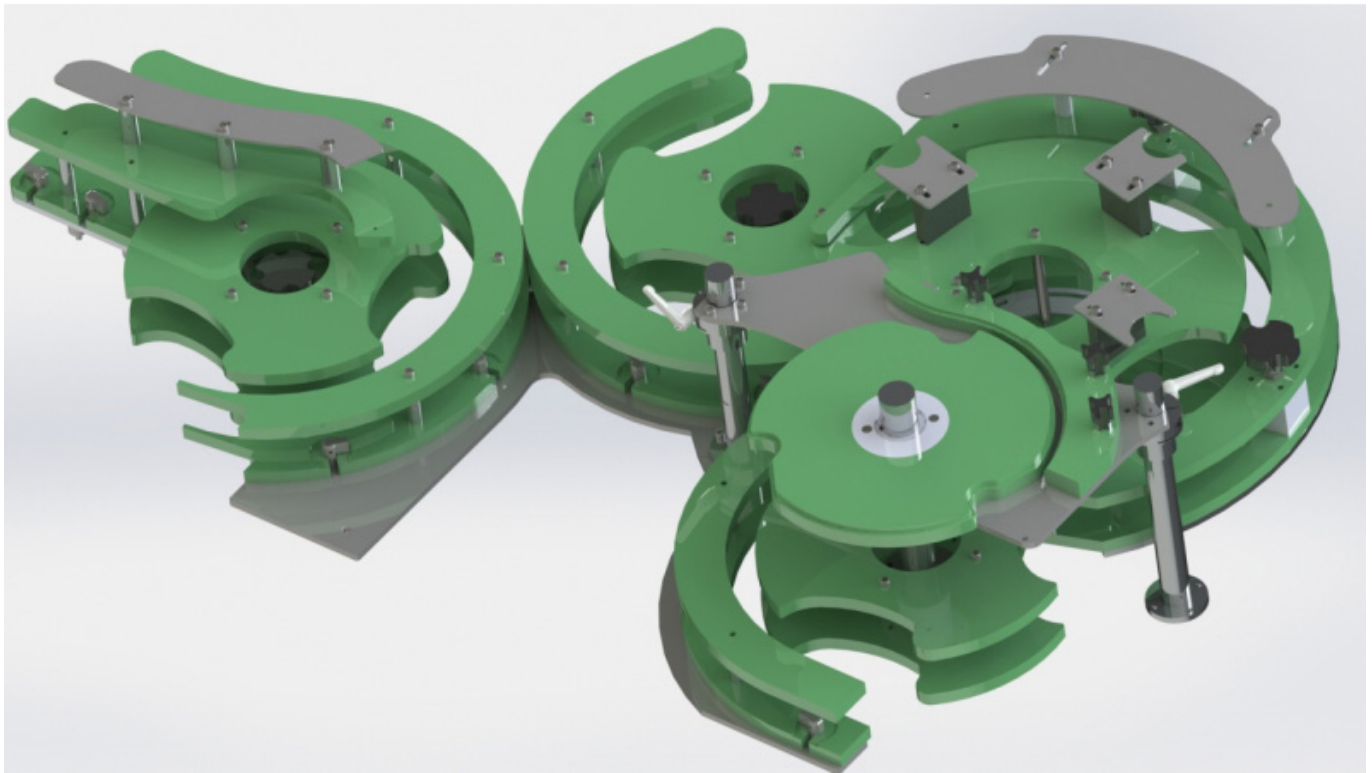
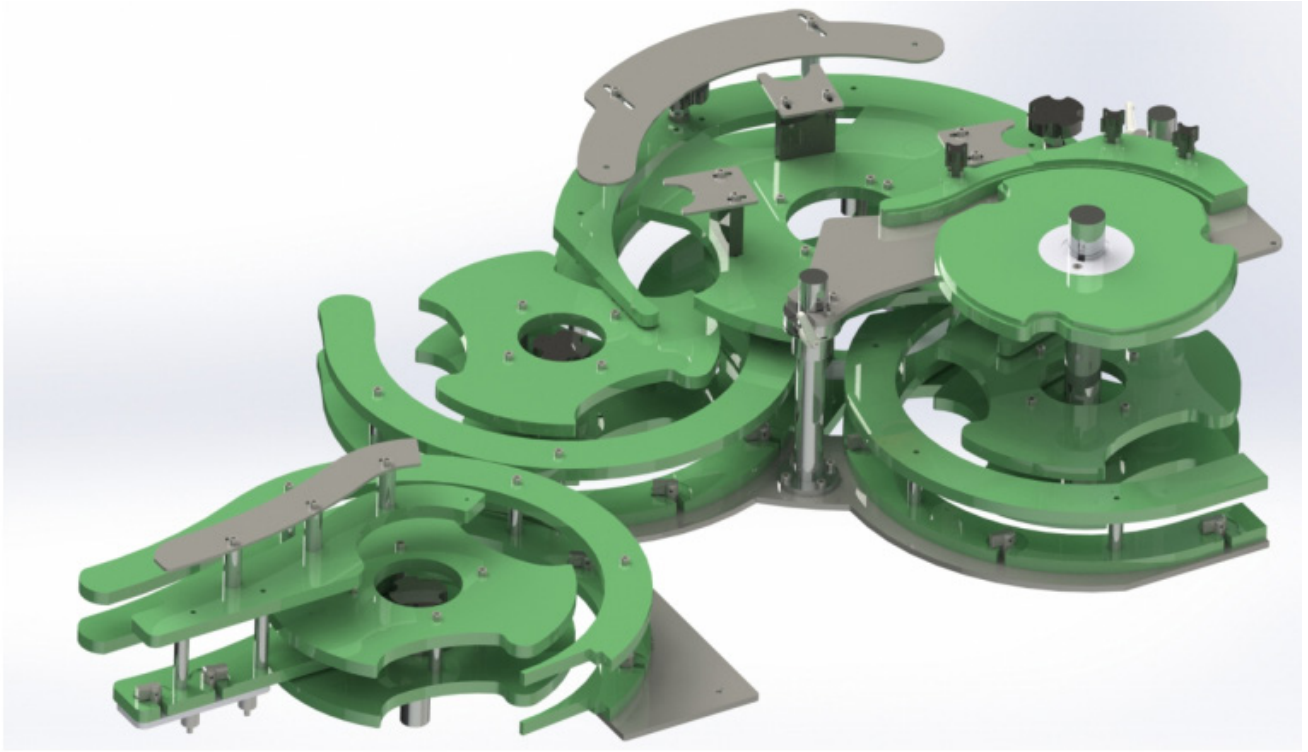

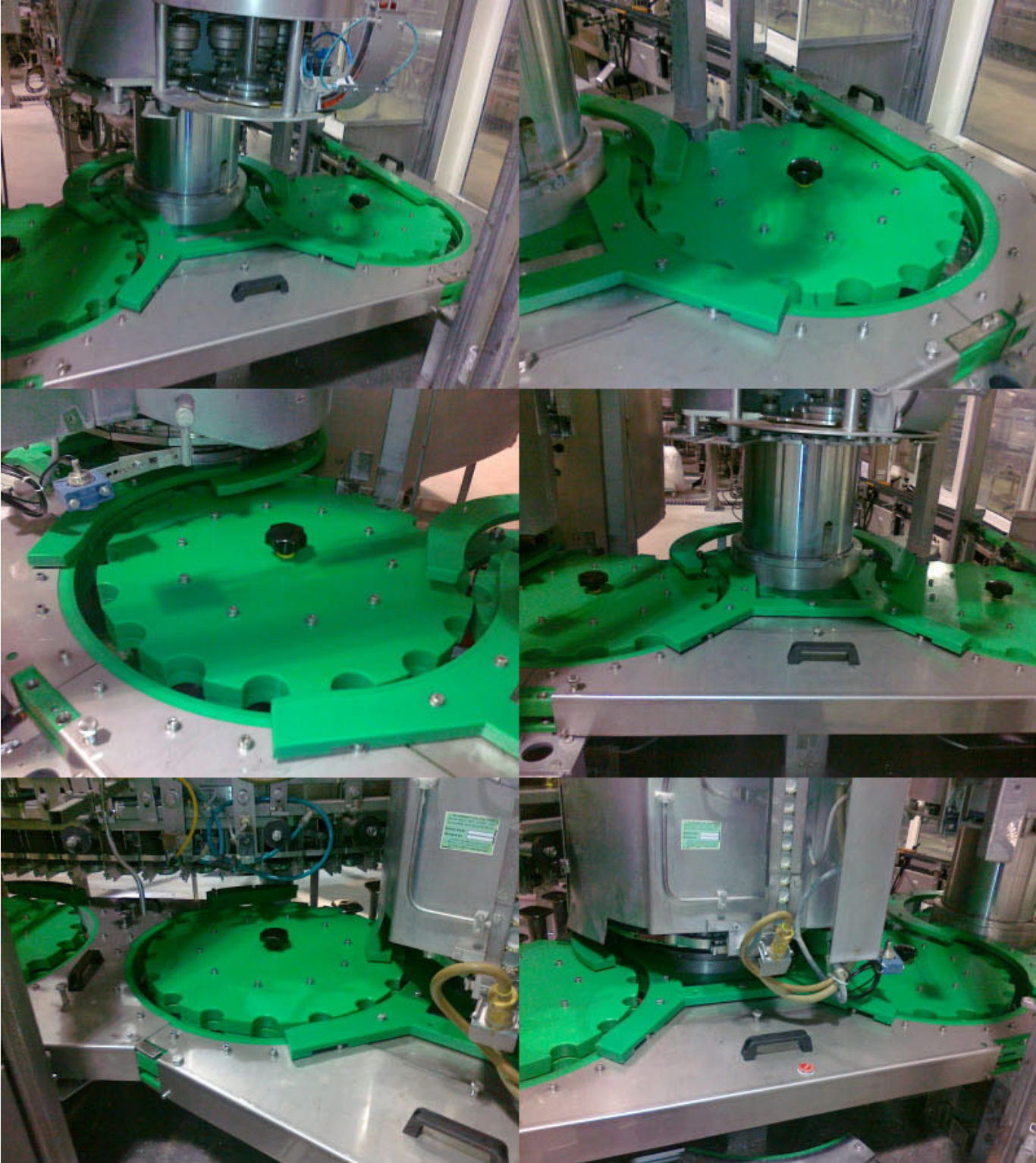
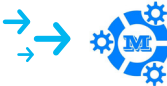

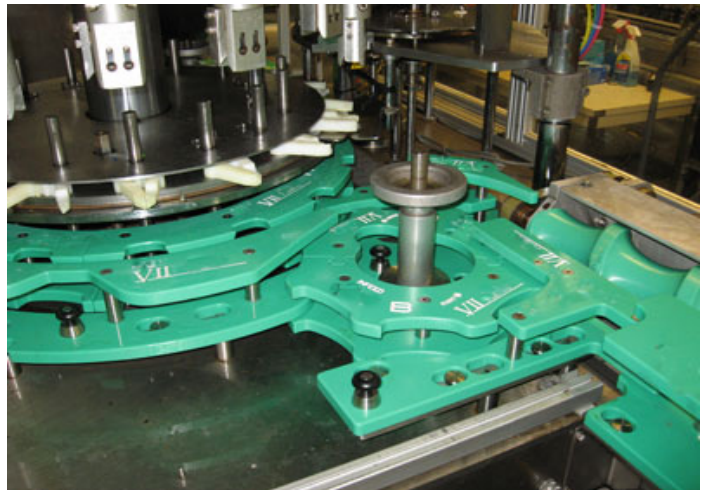

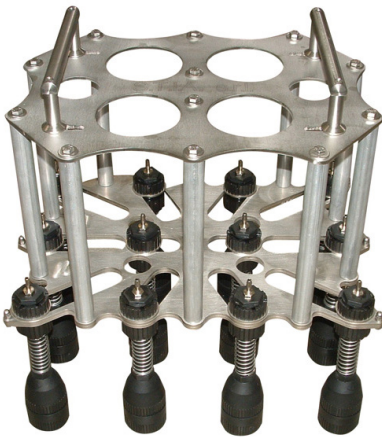

MK-20-1

- MEFE Robotic Bottling Pick-up Heads can be the best solution to your bottle handling needs. These grippers can lift, move, pack, and unpack bottles and similar objects of varying forms and dimensions. We offer a large variety of high quality bottling pick-up heads, ensuring that your bottles can be efficiently handled using simple movements and a strong grip.



MK-20-2

- Choosing the Right Pick-Up Head:
- It is important that the correct pick-up head be chosen for your application. The size and shape of your bottle are the most important factors, but the internal materials that grip the bottle should also be considered in order to get the most out of your equipment. Contact our Technical Sales department and let us assist in finding the right Pick-up Heads for you.

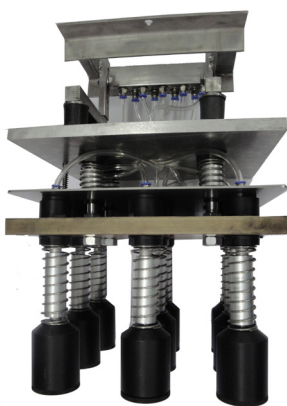

MK-20-3

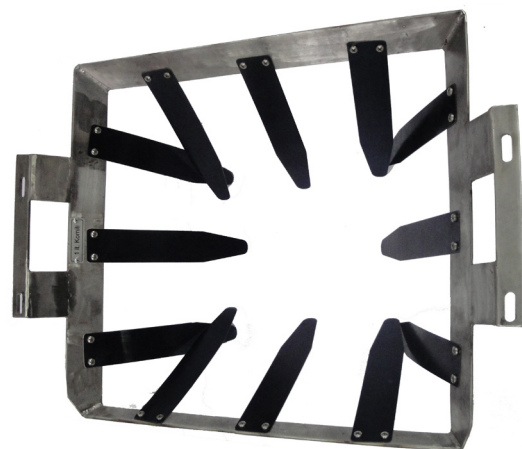

MK-20-4

BOTTLING LINE CHANGE PARTS

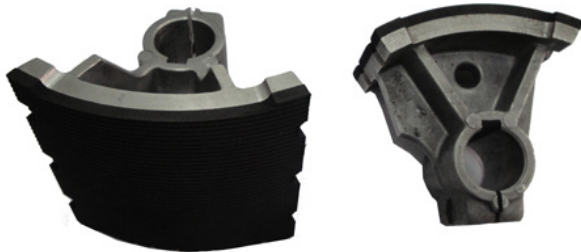

- Labeler Change Parts requirements! Discover the same high level of precision design and engineered products, quality, and service that our Customers have experienced since 2000.
- MEFE commitment to state-of-the-art engineering, manufacturing processes, and Research and Development ensures the highest level of quality Change Parts available. Our experienced team of changeover experts will build upon the OEM standard to enhance the fit and function of the parts.
- In manufacturing the Labeler components, MEFE uses FDA approved materials and stainless steel construction, rather than chrome-plated parts. Magazine frames are composed of precision machined components, with no forged or bent metal parts. All components are new; there are no refurbished parts. Stainless steel electro polished surfaces on the slides enhances label feed performance. The materials and construction provide durability and longevity.

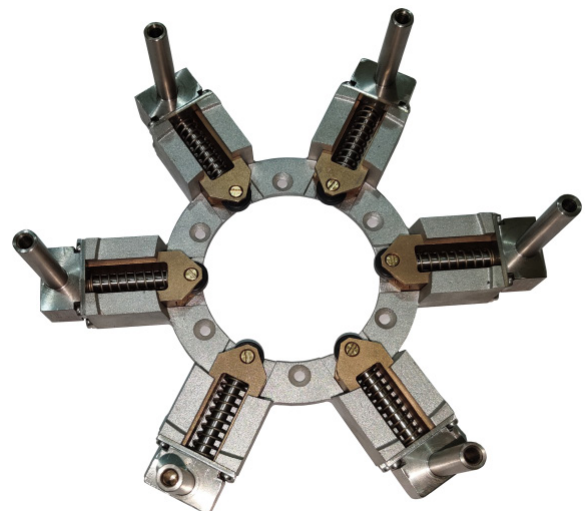



Special gripper with sliding mechanism

MEFE Gripper Cylinders are lightweight with long lasting cams and cam rollers.

Our Pushout Slide Assembly is designed to extend the life of your gripper.

MEFE MAKINA MUHENDISLIK also supplies size parts to fit all types of All type machine's labelling machine and all performance categories.

- Labeler Change Parts requirements! Discover the same high level of precision design and engineered products, quality, and service that our Customers have experienced since 2000.
- MEFE commitment to state-of-the-art engineering, manufacturing processes, and Research and Development ensures the highest level of quality Change Parts available. Our experienced team of changeover experts will build upon the OEM standard to enhance the fit and function of the parts.

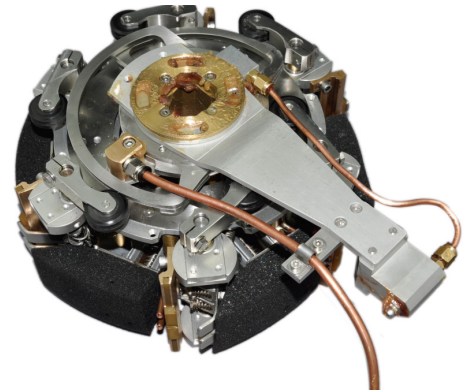

THE BENEFITS TO YOU:

- > Available for all technologies and performance categories
- > Superior quality of workmanship and stability
- > Make use of your machine's full potential
- > Fittings are quick and easy to change

We have been working closely with leading companies in the spirits industry for many years. They set extremely stringent requirements for their premium products in terms of quality of workmanship. Truly unique solutions are required to process the unusual and ever-changing bottle and label shapes used for these products. Thanks to this expertise, MEFE is your ideal partner if you are looking to use your All type machine's labelling machine to implement new and original ideas.



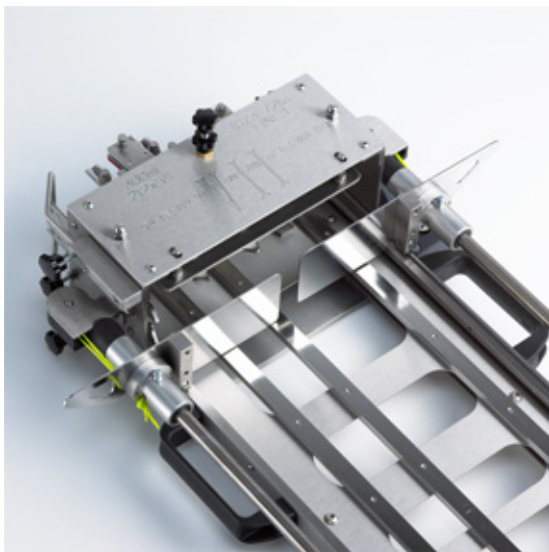
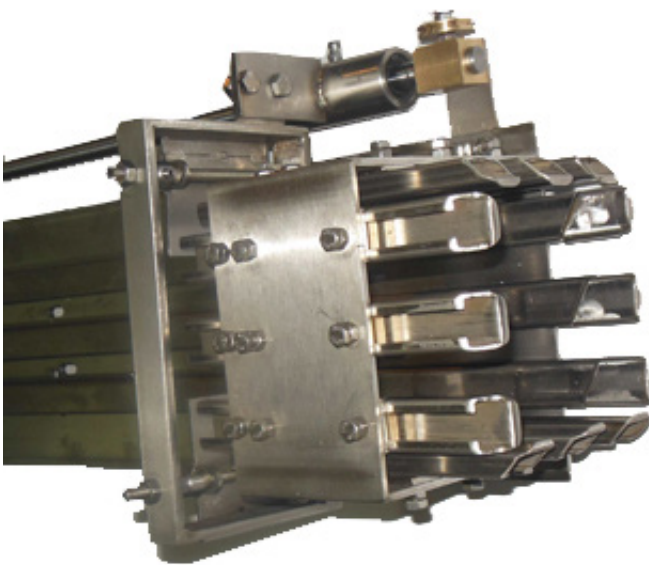
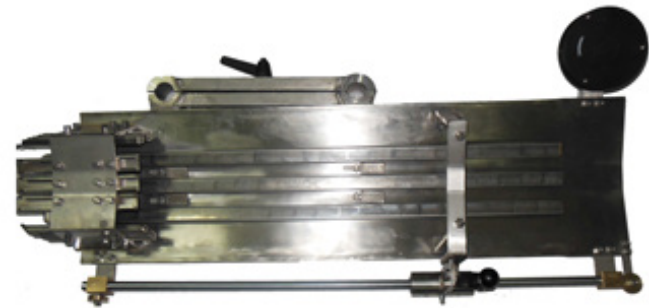

- Labeler Change Parts requirements! Discover the same high level of precision design and engineered products, quality, and service that our Customers have experienced since 2000.
- MEFE commitment to state-of-the-art engineering, manufacturing processes, and Research and Development ensures the highest level of quality Change Parts available. Our experienced team of changeover experts will build upon the OEM standard to enhance the fit and function of the parts.
- In manufacturing the Labeler components, MEFE uses FDA approved materials and stainless steel construction, rather than chrome-plated parts. Magazine frames are composed of precision machined components, with no forged or bent metal parts. All components are new; there are no refurbished parts. Stainless steel electro polished surfaces on the slides enhances label feed performance. The materials and construction provide durability and longevity.
- MEFE will supply new Label Handling Change Parts manufactured to the highest standards. We will engineer your project on the latest CNC Technology and deliver change parts that fit precisely on your machine complete with drawings and parts list for each package. All components are interchangeable with the OEM.

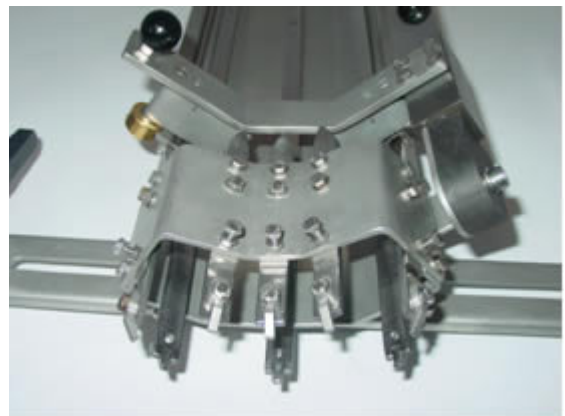

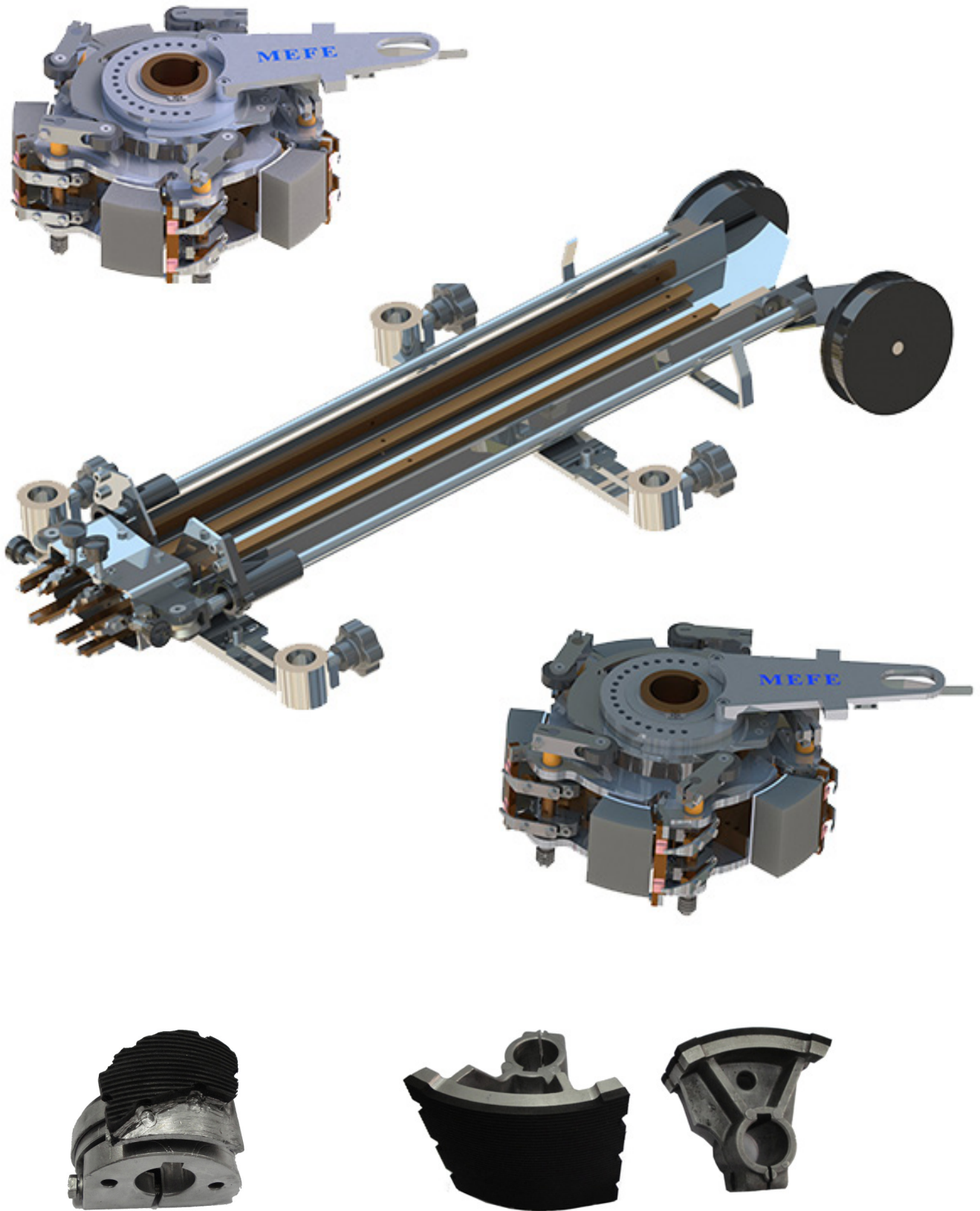

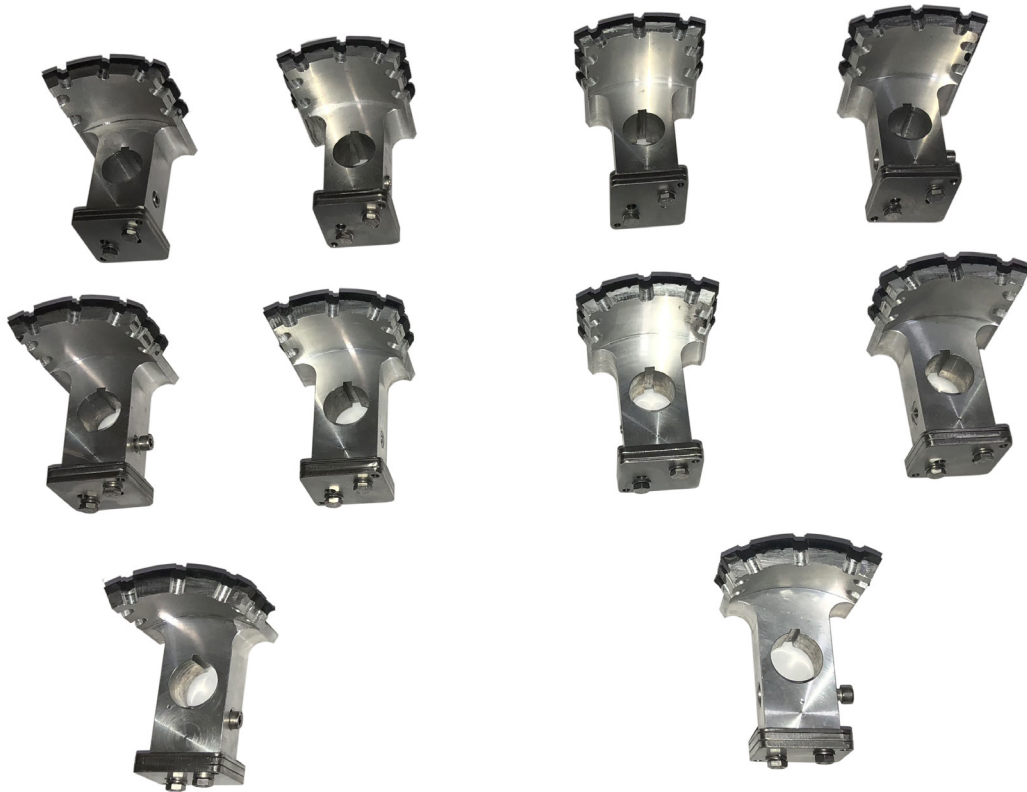



Glue Pallet Shaft





LABELLING GLUE PALLET

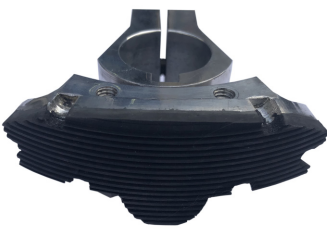

Glue Cylinder & Shaft

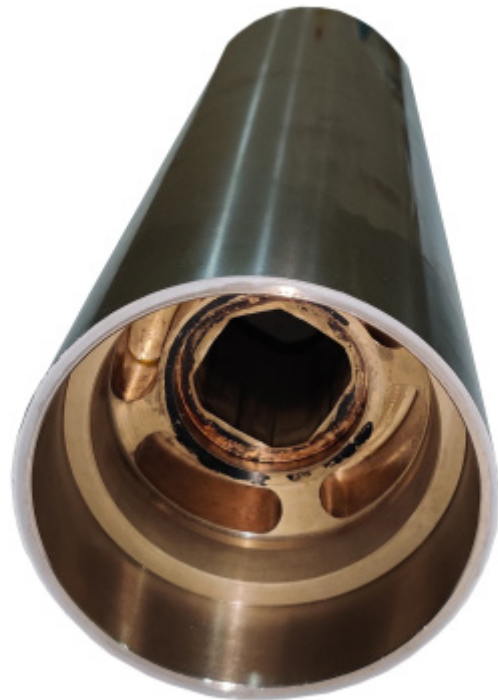

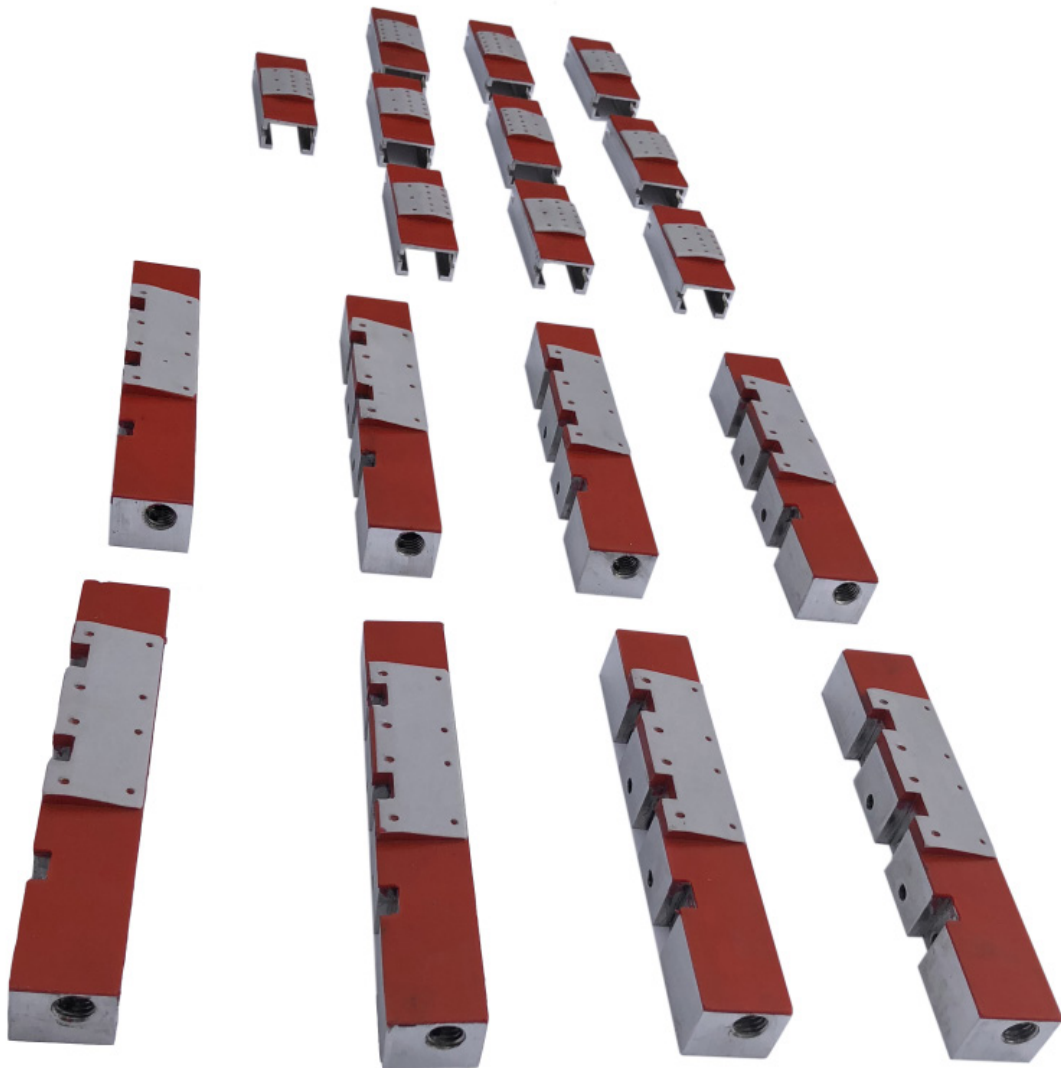

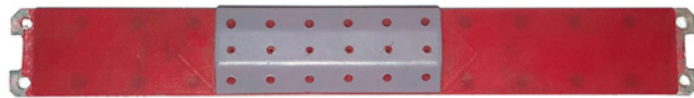
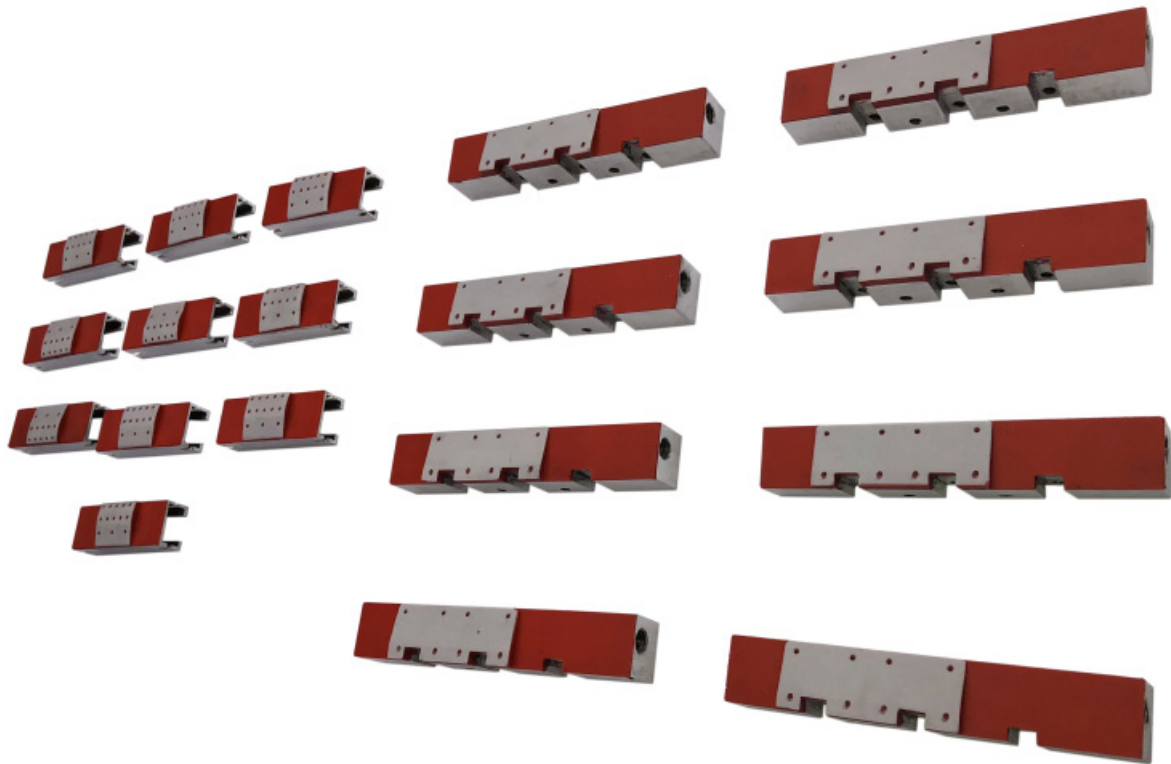

VACUUM DRUM VACUUM PADS

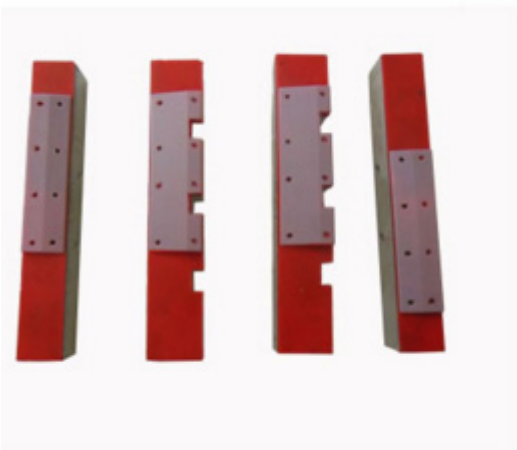

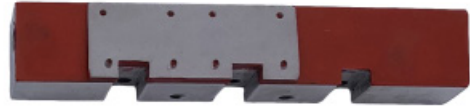
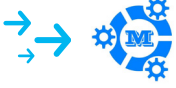

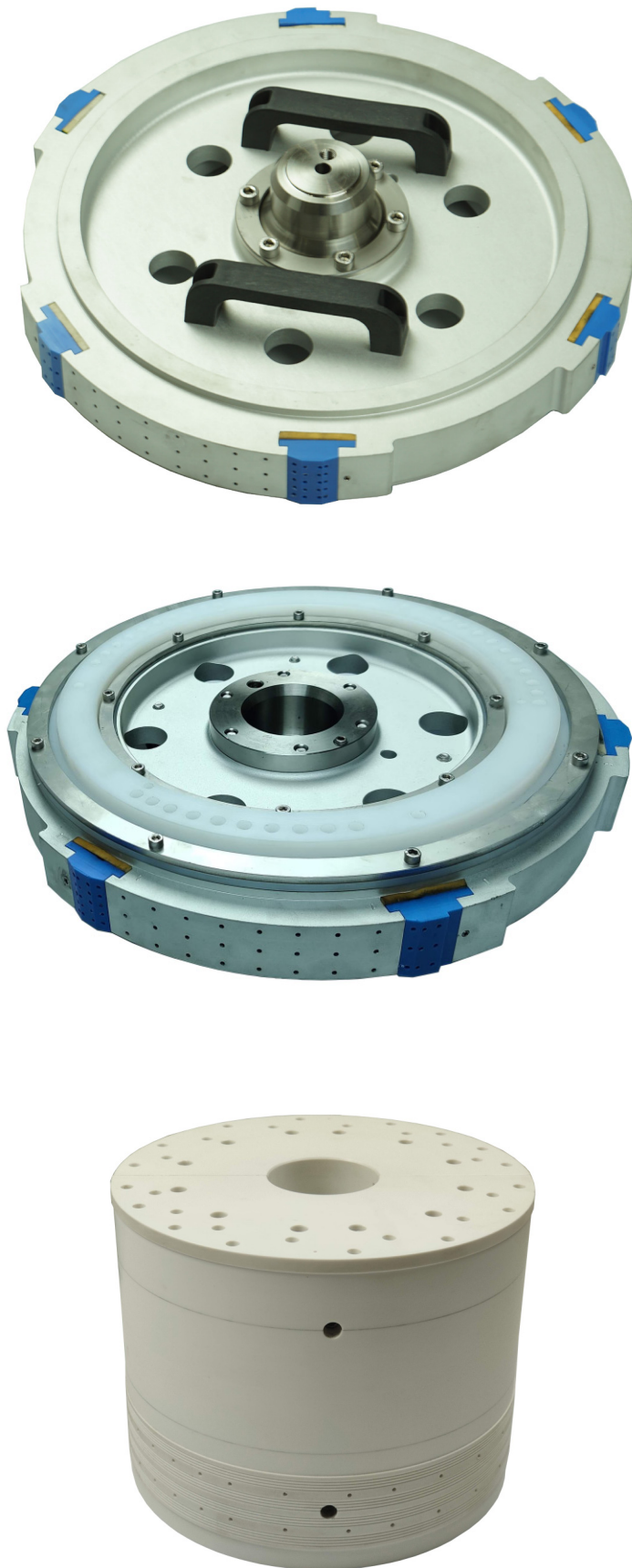

- Vacuum drums are an integral component of the MEFE series of labelers. For optimal performance, vacuum drums need to be clean, with the rubber surface free of damage and excessive wear which comes after a prolonged period of constant use.
- MEFE Labeling offers a comprehensive vacuum drum repair process. Vacuum drums are inspected, thoroughly cleaned, re-surfaced and machined by our highly trained personnel.
- In addition to repairing MEFE vacuum drums, we also repair those of many other manufacturers.
- Contact us to schedule a refurbishment of your vacuum drum(s). MEFE takes great pride in the total flexibility of our product line. As part of this flexibility, we are pleased to offer complete and partial changeover packages for our labelers. The ever-changing market demand will constantly require new container formats and we recognize this. Simply let us know what you need and when you need it and we will be pleased to provide a quote and delivery time for the genuine MEFE parts you require to produce any new formats.



ROLL FEED O.P.P. LABELLING VACUUM DRUM CYLINDER



VACUUM DRUM FOR LABELLING MACHINES



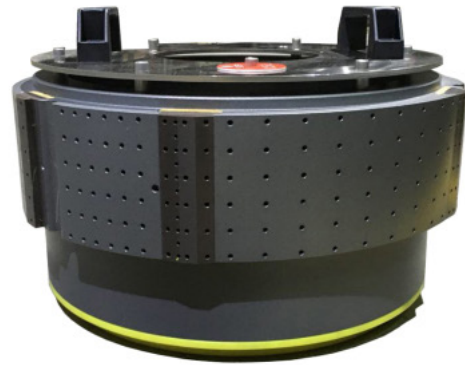

LABELER VACUUM DRUM

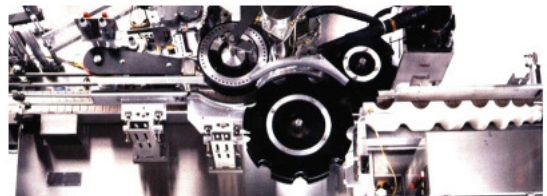
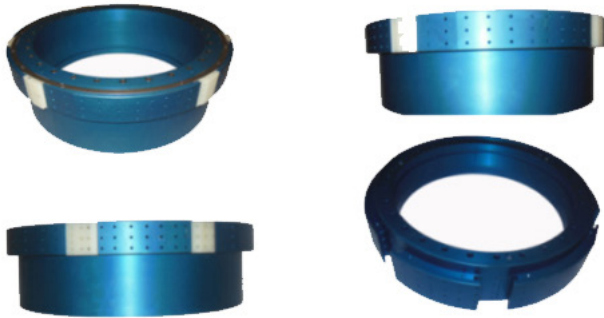

OPP LABELER VACUUM DRUM



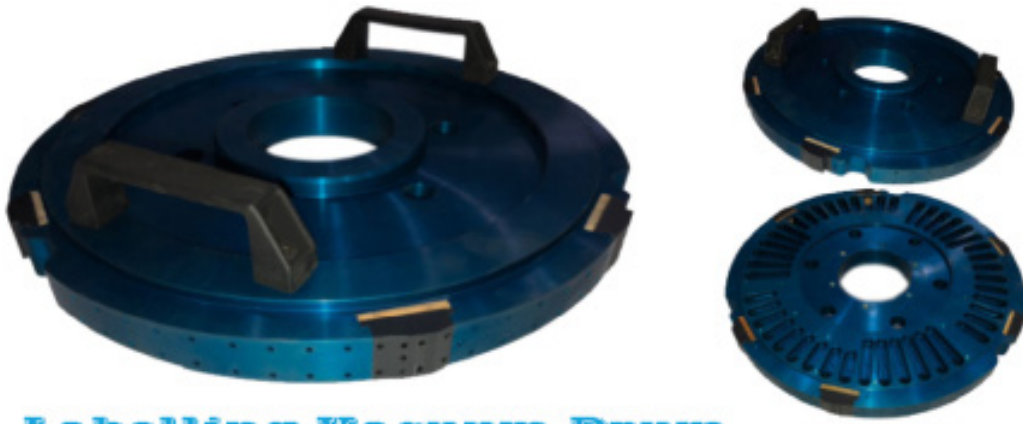

Labelling Vacuum Drum

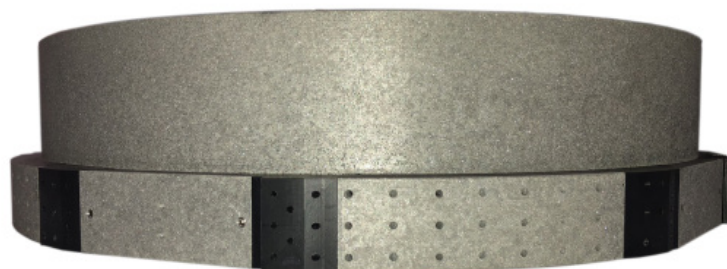
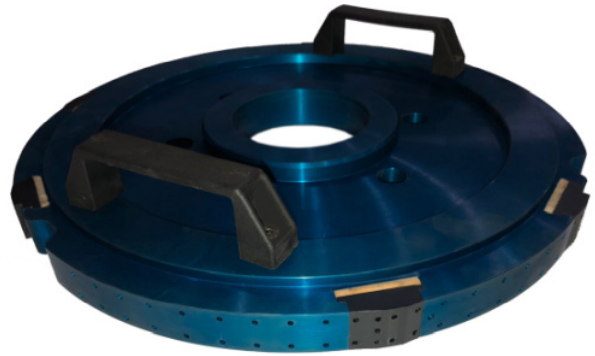
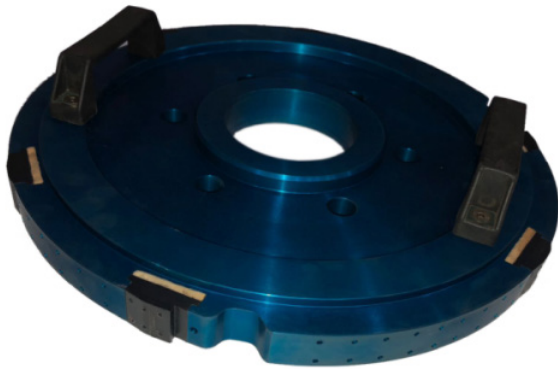

LABELLING MACHINE GLUE SCRAPPER

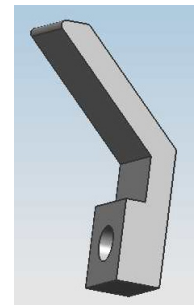
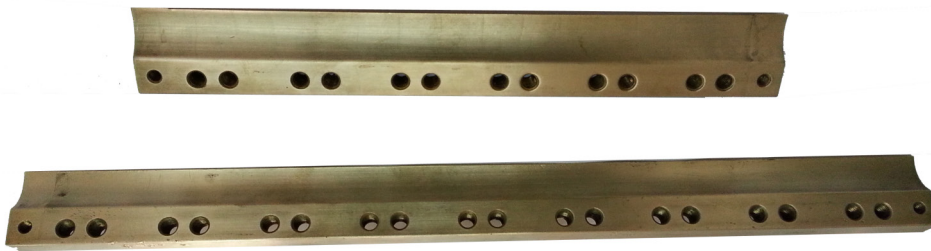
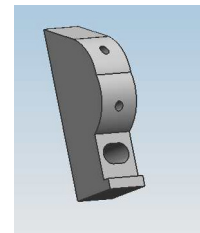
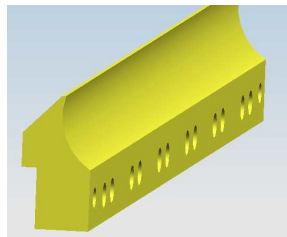
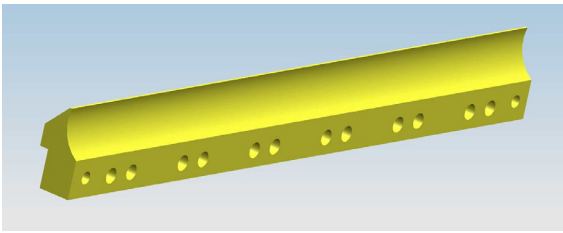

Labeler Bottle Plates

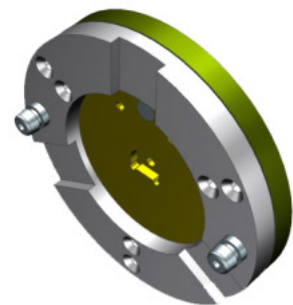
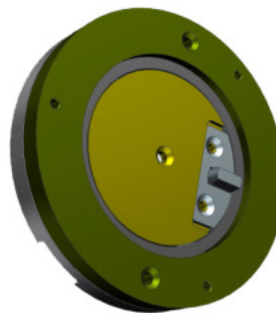
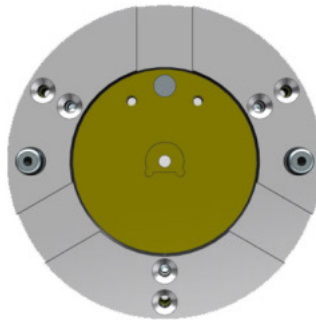
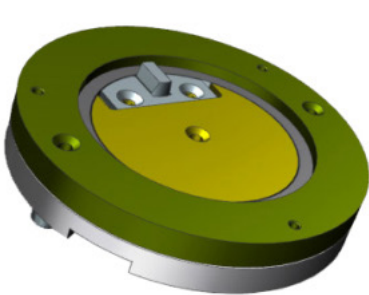

Labelling Machine Brushes



Labelling Machine Sponge



MP-54-1



MP-54-2



MP-54-3



MP-54-4



MP-54-5



MP-54-6



BOTTLE PLATES

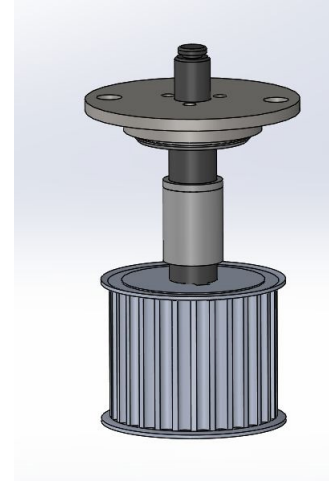
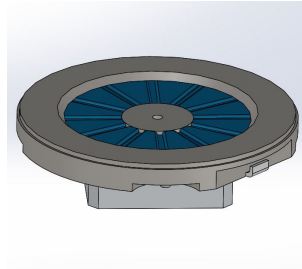
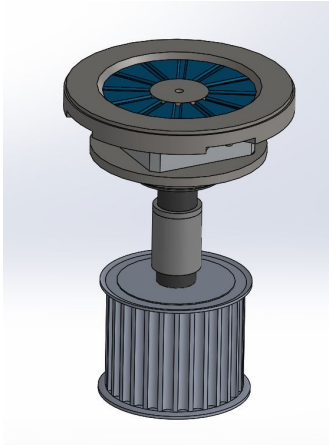

LABELING MACHINE CENTERING HEAD



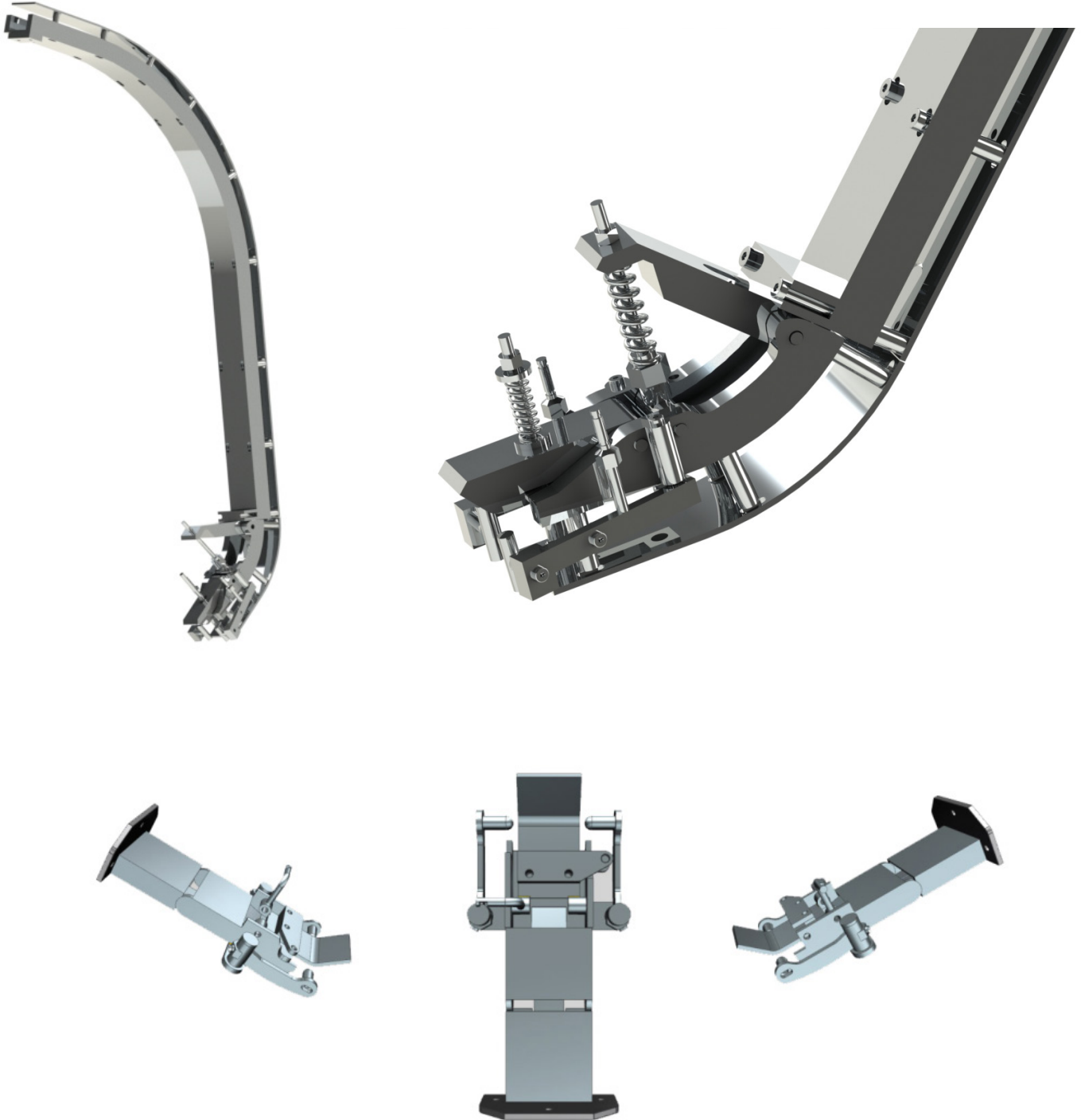

Capping Pick Of Head Parts

Anti-Rotation Knives**ARK-1****ARK-2****ARK-3****ARK-4****ARK-5****ARK-6**

- .Manufactured from highly corrosion resistant hardened stainless steel material
- .Unique five point knife designed to last longer than other anti-rotation knives
- .Three hardness levels available to fit your application requirements
- .Hardness levels up to 78 Rc
- .100% interchangeable with OEM anti-rotation knives
- .Quick delivery



Standard Chucks

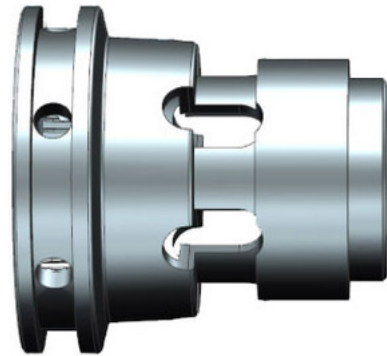
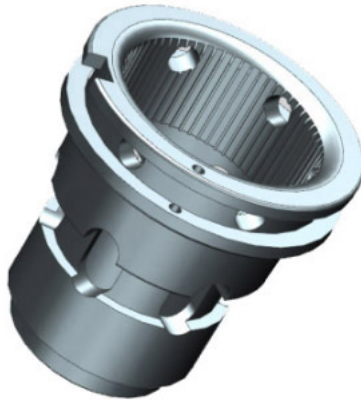

CAPPING CHUCKS



Various types Chucks



Capping Magnate Part

RINSER MACHINE GRIPPER HEAD

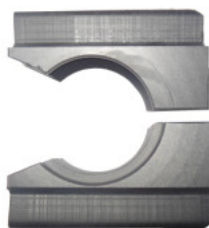
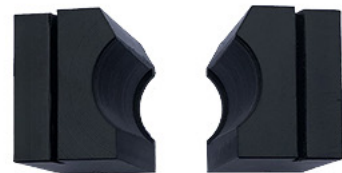
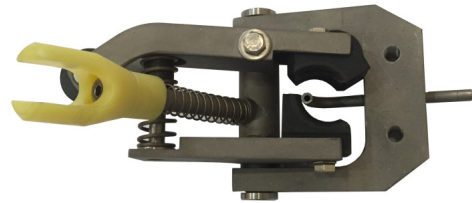

RINSER GRIPPER

RINSER MACHINE GRIPPER HEAD

Rinser Gripper

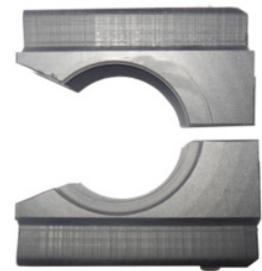
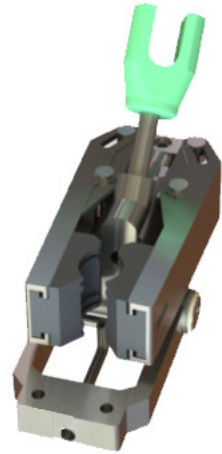
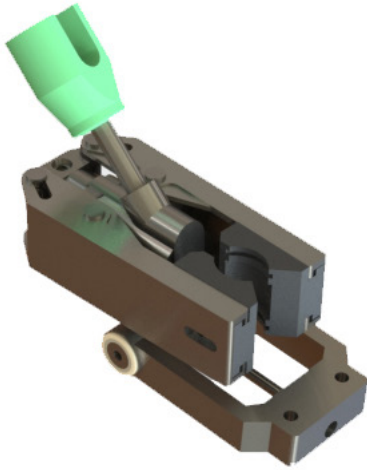

RINSER GRIPPERS

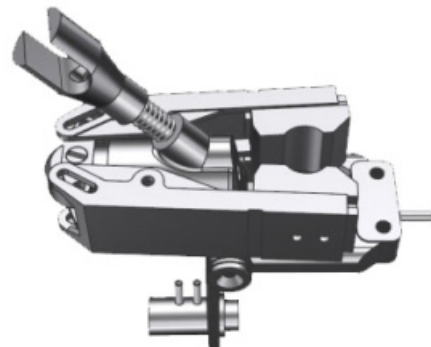

COMPLETE RINSER GRIPPER



Filling Vent Tube Sprays



Filling Vent Tube Sprays



Filling Machine Vent Tubes



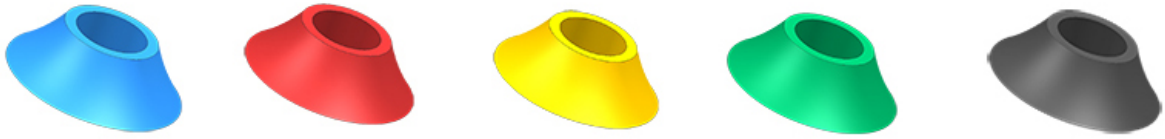

VENT TUBE SPRAYS

- * Available 6 different colour
- * EPDM Rubber 70-75 Shore
- * Alcohol resistant
- * Food Contact Material

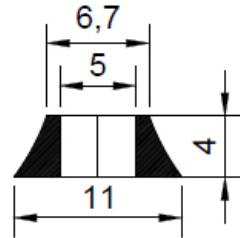

SEM-1

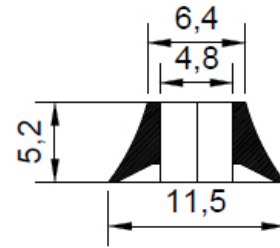

SEM-2

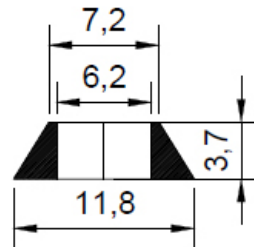

SEM-3

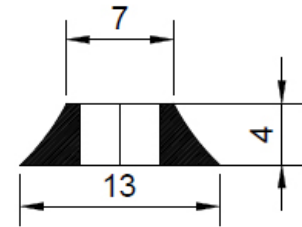

SEM-4

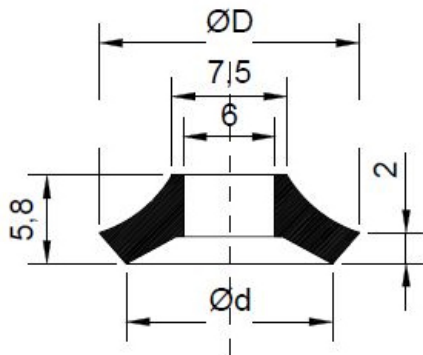

SEM-5

Code	ØD	Ød
SEM5-1	17	13,4
SEM5-2	19	15,4

Bottle Centering Seals

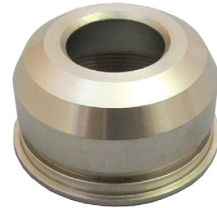
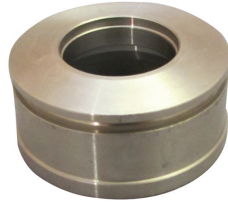

**KHS FILLING PINION
H20433010364**

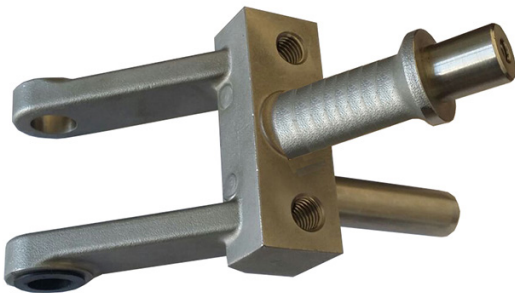



Blowing Preform Pet Gripper



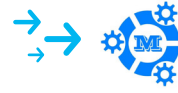



VALVE RUBBER GASKET

We are specializing in manufacturing rubber valve of butterfly valves, check valve, ball valve systems and components according to customers' samples and/or drawings.

Rubber compound can be mixed to include high abrasion resistance, non-marking, weather aging, ozone and oil resistant characteristics.

MEFE can analyze your requirements, make recommendations, and supply the complete solution to all your valve will meet your custom needs. Contact us and we will do our best to find what you are looking for.

MEFE, a variety of the butterfly valves we supply are custom made, and we are capable of attaining many other specifications that will meet your custom needs. Contact us and we will do our best to find what you are looking for.

Material: SBR, Neoprene(CR), Nitrile(NBR), Natural Rubber(NR), EPDM, Silicone, FKM HNBR, IIR, ACM, Fluorosilicone etc.

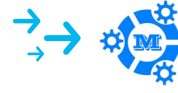

RUBBER SLICONE REPAIR KIT





RUBBER GASKET - O RING

MEFE has FDA compliant elastomers for applications involving rubber compounds interacting with food and beverages. At MEFE our FDA compliant rubber compounds are put through rigorous testing to meet the demands of the most challenging food and beverage applications. We are proud to offer several lines of rubber o-rings that meet these stringent demands, however, we also offer specialized rubber hoses, seals, and gaskets that can be custom molded to your specific specifications. The table shown below expresses some of the key features of MEFE's premium FDA compliant rubber hose lines

MEFE is proud to offer our line of FDA compliant food grade elastomers for food and beverage applications. Currently we are manufacturing three compounds, EPDM, NBR, and VMQ that meet these rigorous specifications. All of our FDA compliant and food grade rubber seals and gaskets are custom molded to your exact specifications to ensure performance specifications are achieved. MEFE is also pleased to have a standardized line of rubber o-rings, in various sizes, shapes and durometers that meet the NSF/ANSI Standard 61 and FDA criteria for food and beverage processes. However, if you do not see the specifications you are looking for please contact our engineering department for more information.

• Machine Reconditioning and Rebuilds

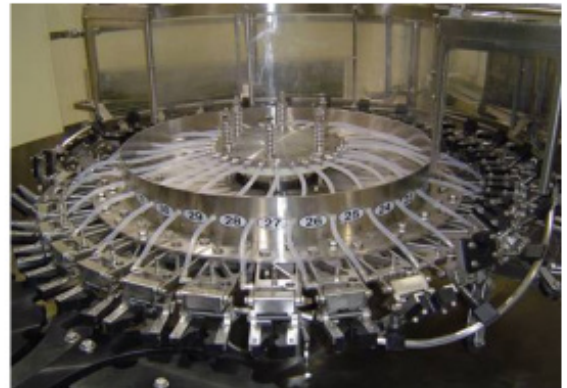

- Repair or replace as necessary all conveyor guide rails.
- Replace all container wrap parts.
- Repair or replace as necessary conveyor sprockets, bearings, bushings, tabletop as necessary.
- Factory test of machine with all required change parts.
- Must pass all test procedures of Label Masters very strict quality control program.





Tapered conveyor rollers

We manufacture tapered rollers to suit an inside radius of either 500mm or 800mm. Both sizes can be assembled with a choice of bearing types to suit your requirements. Free running bearings are best suited to gravity conveyors, while precision bearings are usually fitted for continuous running applications such as grooved or sprocket driven rollers.

Features and options:

Free running option for gravity roller conveyors

All tapered conveyor rollers have a sealed bearing option for wash-down areas

50mm diameter base roller can be grooved for lineshaft conveyors

Single or double 14 tooth x 1/2" sprockets can be fitted (choice of steel or nylon sprockets)

Grade 316 stainless steel base roller tube and spindle options



CAP SORTER-ELEVATING PREFEEDER



CAP ELEVATING PREFEEDER: KE25-1



CAP SORTING: KD25-2



CAP SORTING KD25-4

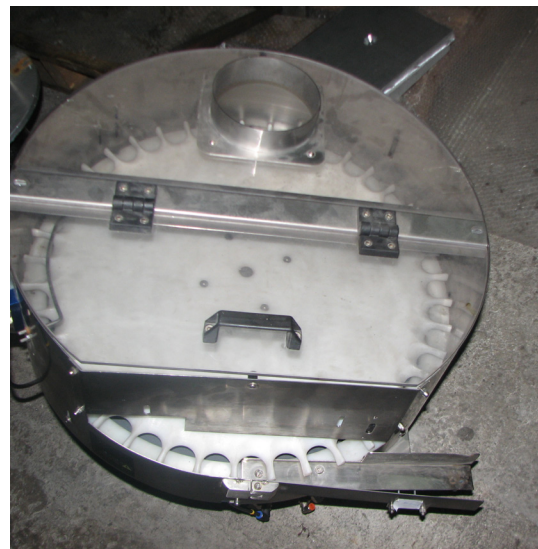

CAP SORTING :KD25-3

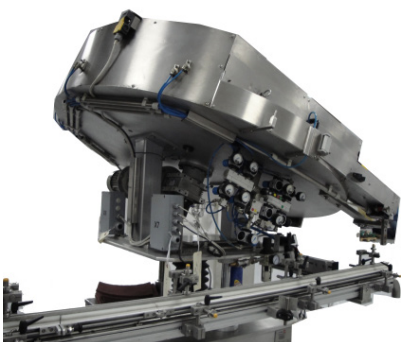

CAP SORTING KD25-5



CAP SORTING: KD25-6

TABLE TAB CONVEYORS



TABLE TAB CONVEYORS



ROLLER CONVEYOR



KA27-1



KA27-2

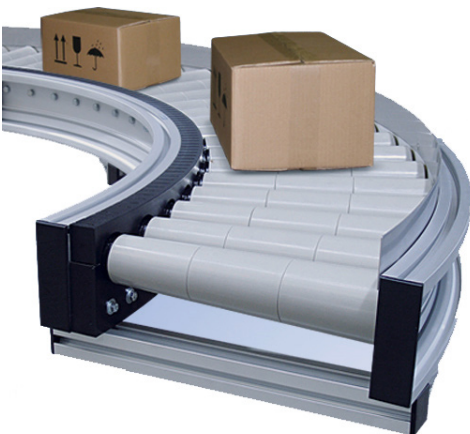

KA27-3

Roller Diameter	Shaft Diameter	Cap Type
Ø 16	Ø 6	Plastic
Ø 20	Ø 8	Plastic
Ø 30	Ø 10	Plastic
Ø 30	Ø 10	S.Steel
Ø 40	Ø 10	Plastic
Ø 40	Ø 12	S.Steel
Ø 50	Ø 12	Plastic
Ø 50	Ø 12	S.Steel
Ø60	Ø12	Plastic
Ø60	Ø12	S.Steel
Ø70	Ø17	S.Steel
Ø80	Ø15	Plastic
Ø80	Ø17	S.Steel
Ø89	Ø20	Plastic
Ø89	Ø25	S.Steel
Ø108	Ø25	Plastic

- We make a wide range of Roller Conveyors classified as - Powered and non powered version conveyors using standard Precision bearings for heavy loads (250 kgs and above) and pressed bearings for lighter loads.
- Many combinations offered in terms of Roller Pitch, Roller Diameter, Roller Moc, between frame width. Rollers are spring loaded with Hex axle or round axle. Please ask for our detailed catalogue
- Roller conveyors consist of a series of rollers attached to a rigid, horizontal frame. Goods move over the top of the rollers from one point to another. Transported items generally have a flat base (pallets, containers, boxes, cartons). A choice between motorized and mechanical rollers is available. The application will determine the best configuration: gravity, curved or line shaft..

CONVEYOR GUIDE CURVE

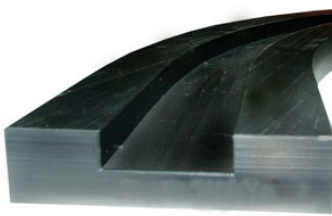

MP-52-1



MP-52-2



MP-52-3

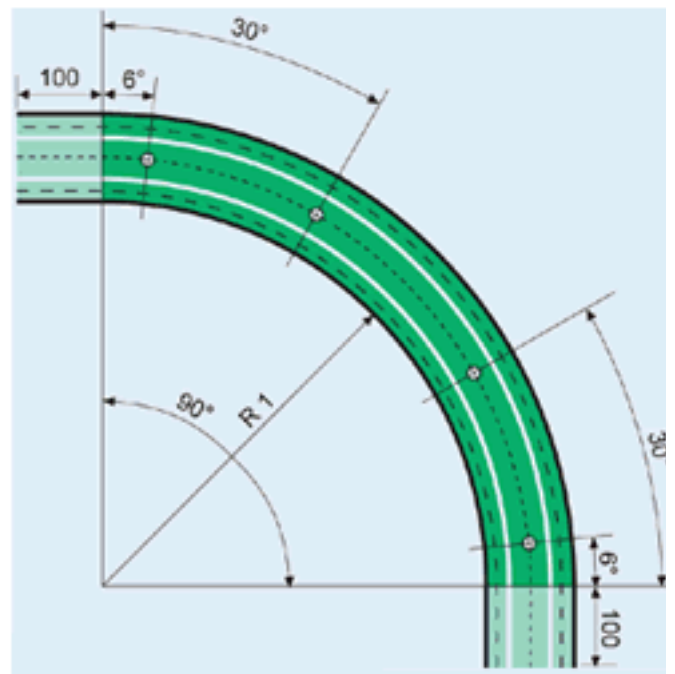
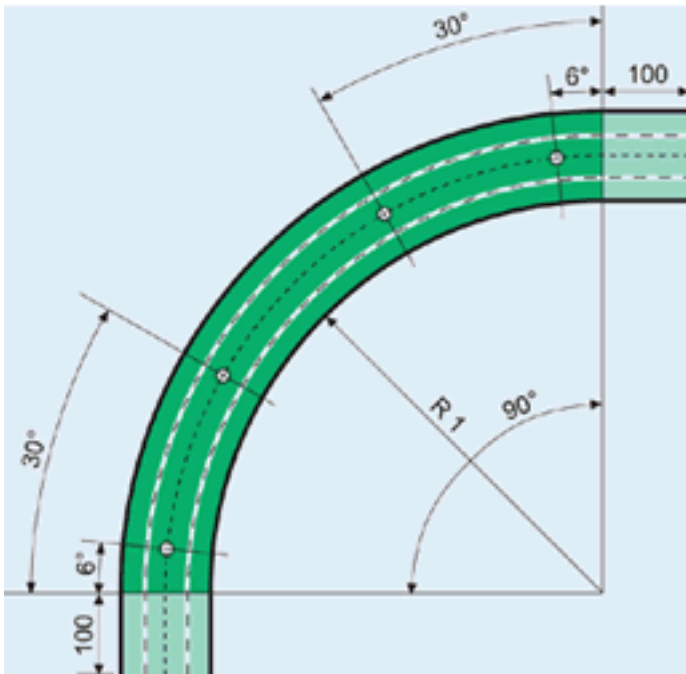

MAGNET CURVE



CHANGE PARTS & SPARE PARTS

MEFE



CONTACT US



MEFE MAKINA MUHENDISLIK SAN. VE TIC..LTD.STI.

LIKITELLI OSB.DEMIRCILER SANAYI SITESI E-2 BLOK

NO:399/B BASAKSEHIR / ISTANBUL/TURKEY

TEL:+90.212 671 72 83 FAX:+90.212 671 72 84

www.mefe.com.tr

Email: info@mefe.com.tr

Copyright 2019

